



US007915814B2

(12) **United States Patent**  
**Matsudate et al.**

(10) **Patent No.:** **US 7,915,814 B2**  
(45) **Date of Patent:** **Mar. 29, 2011**

(54) **ORGANIC ELECTRO-LUMINESCENT DISPLAY DEVICE**

(56) **References Cited**

(75) Inventors: **Noriharu Matsudate**, Kujukuri (JP);  
**Takeshi Ookawara**, Mobara (JP)

U.S. PATENT DOCUMENTS  
6,538,374 B2 3/2003 Hosokawa  
6,900,470 B2 5/2005 Kobayashi et al.  
2002/0158835 A1\* 10/2002 Kobayashi et al. .... 345/100

(73) Assignee: **Hitachi Displays, Ltd.**, Chiba (JP)

FOREIGN PATENT DOCUMENTS

(\* ) Notice: Subject to any disclaimer, the term of this patent is extended or adjusted under 35 U.S.C. 154(b) by 119 days.

JP 2001-230086 2/2000  
JP 2002-318556 4/2001

\* cited by examiner

(21) Appl. No.: **12/285,688**

*Primary Examiner* — Toan Ton

*Assistant Examiner* — Hana S Featherly

(22) Filed: **Oct. 10, 2008**

(74) *Attorney, Agent, or Firm* — Stites & Harbison PLLC;  
Juan Carlos A. Marquez, Esq.

(65) **Prior Publication Data**

US 2009/0096371 A1 Apr. 16, 2009

(57) **ABSTRACT**

A top-emission-type organic EL display device which exhibits uniform screen brightness is realized by preventing a voltage drop of an upper electrode formed of a transparent conductive film. Pixels each of which is sandwiched between an upper electrode and a lower electrode are arranged in a matrix array to form a display region. An auxiliary electrode extends in the lateral direction between the pixels and the pixels for preventing a voltage drop of the upper electrode. A current supply line which supplies an electric current to the upper electrode and the auxiliary electrodes are made conductive with each other by forming a through hole in an insulation layer. To ensure reliability of connection at the through hole, a contact electrode made of metal which overlaps with the auxiliary electrode is formed on the through hole by vapor deposition.

(30) **Foreign Application Priority Data**

Oct. 10, 2007 (JP) ..... 2007-264503

(51) **Int. Cl.**  
**H01L 51/50** (2006.01)

(52) **U.S. Cl.** ..... **313/505**

(58) **Field of Classification Search** ..... 313/505-506,  
313/504

See application file for complete search history.

**5 Claims, 6 Drawing Sheets**

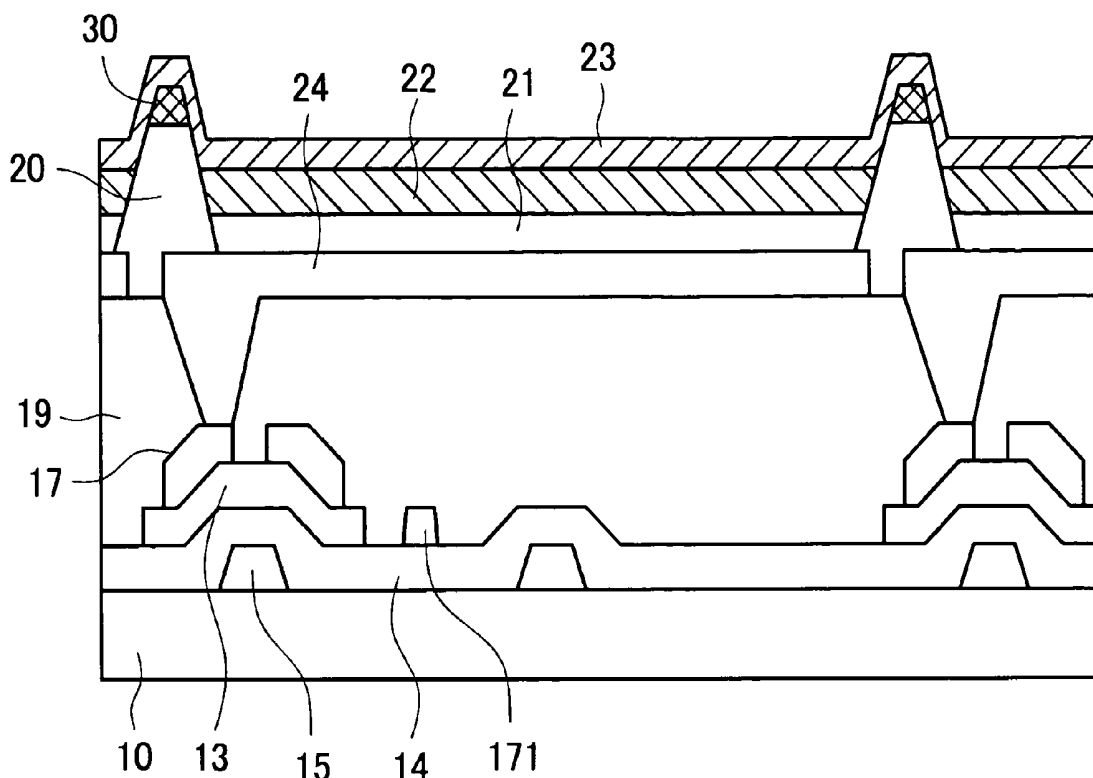

FIG. 1

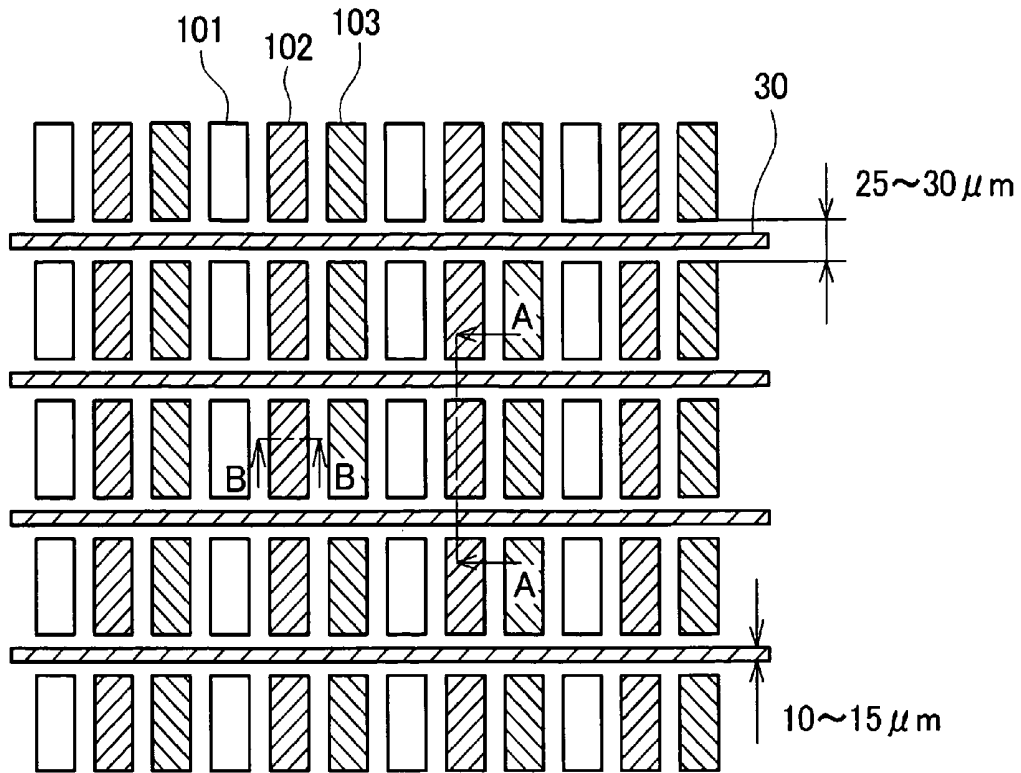

FIG. 2

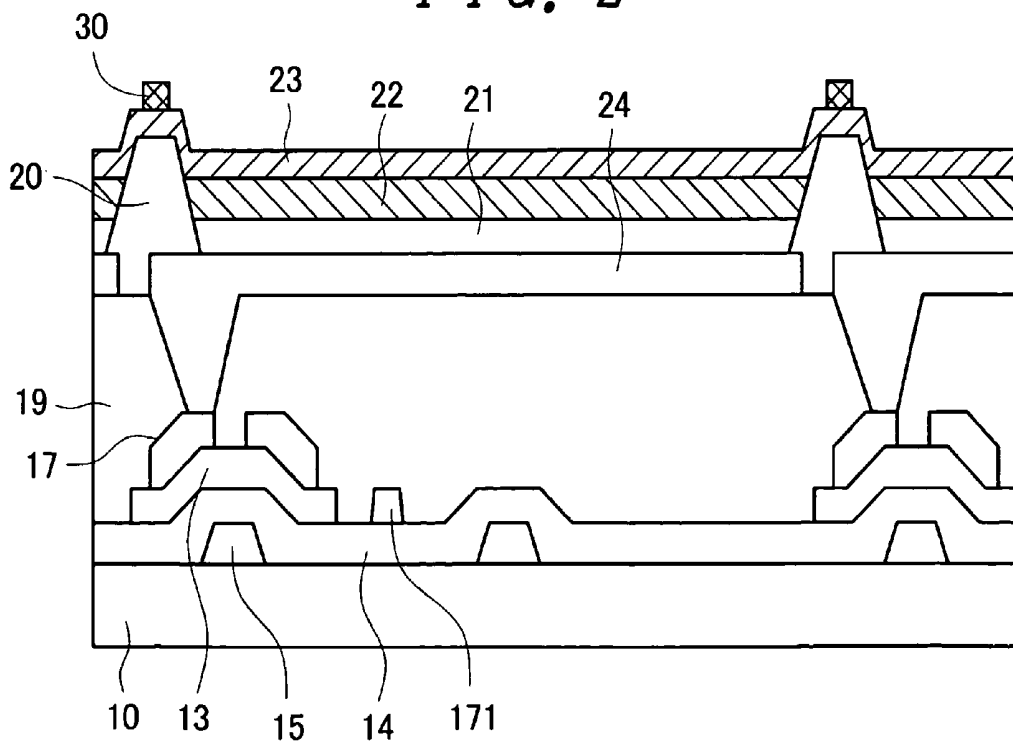

FIG. 3

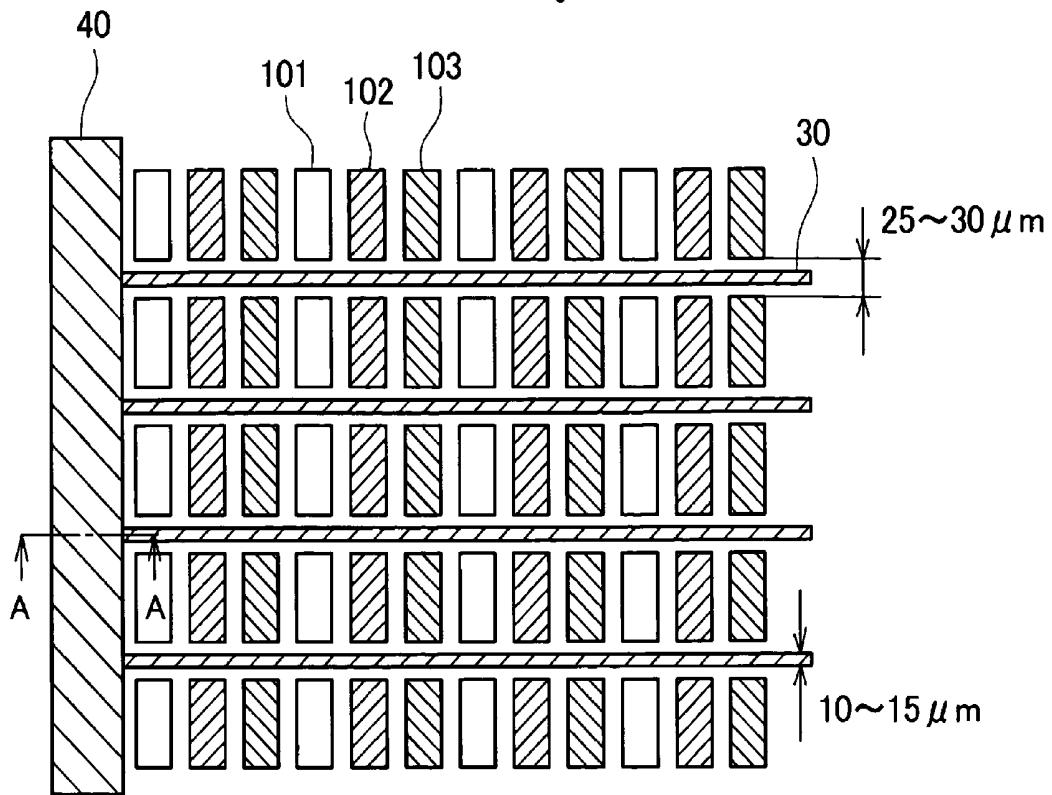

FIG. 4

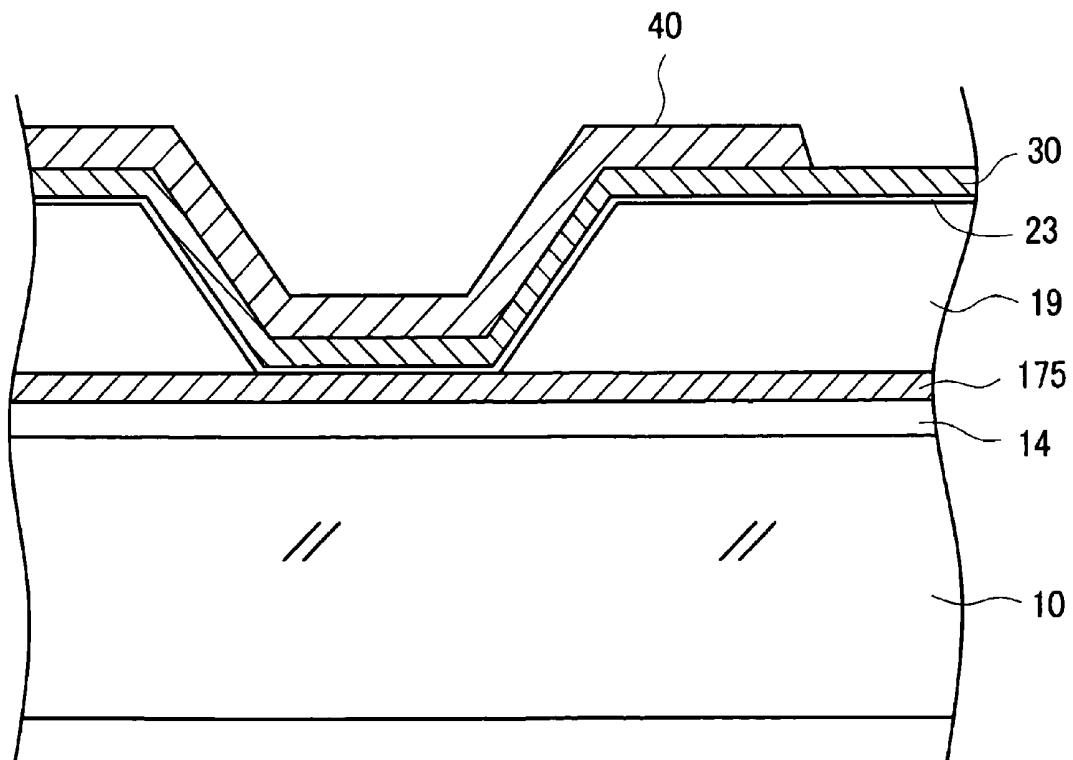

FIG. 5

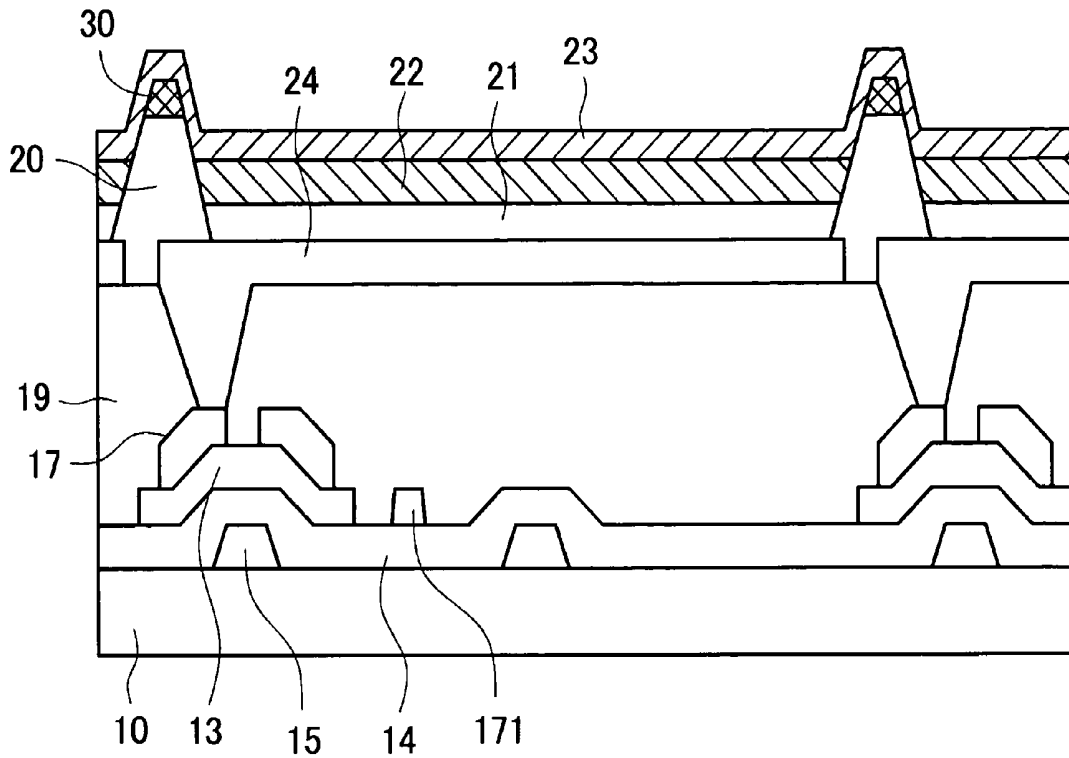

FIG. 6

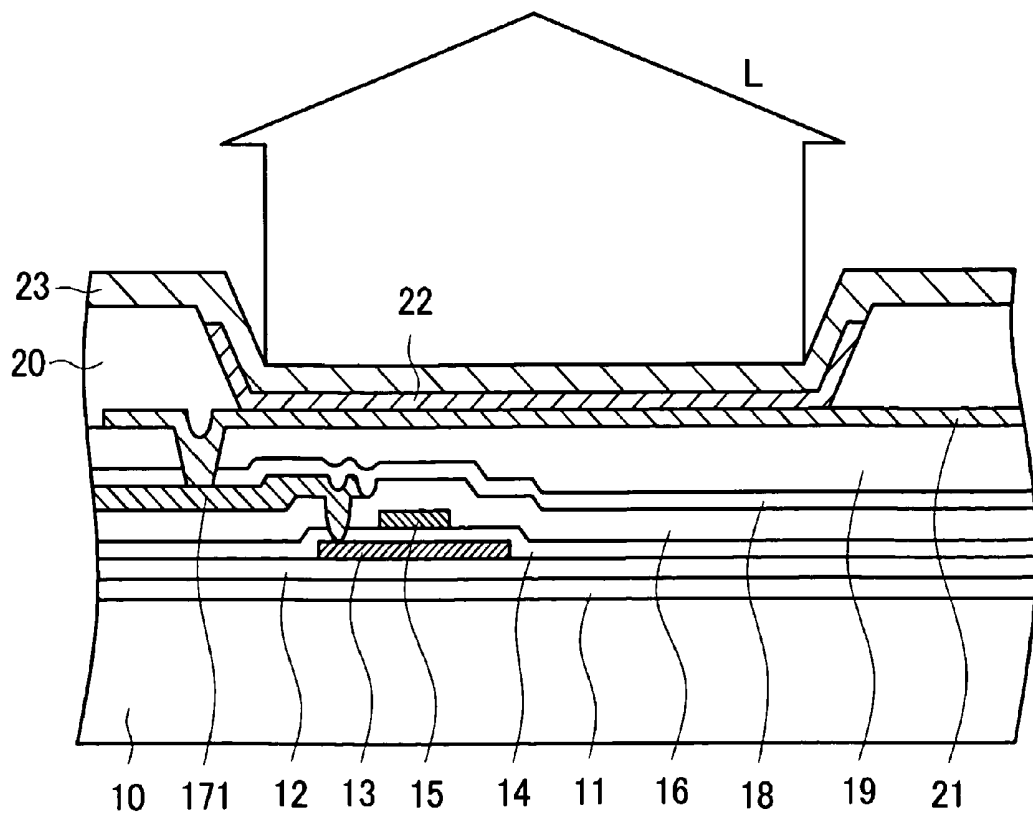

FIG. 7

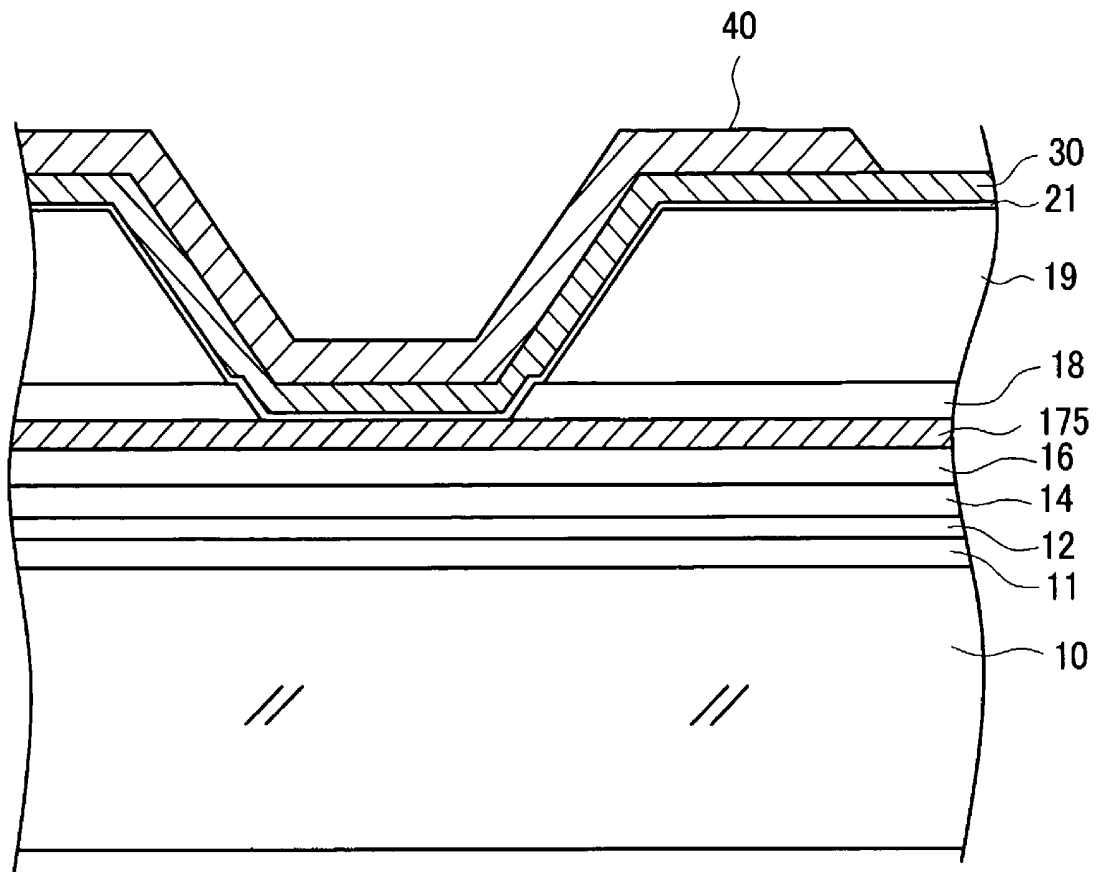
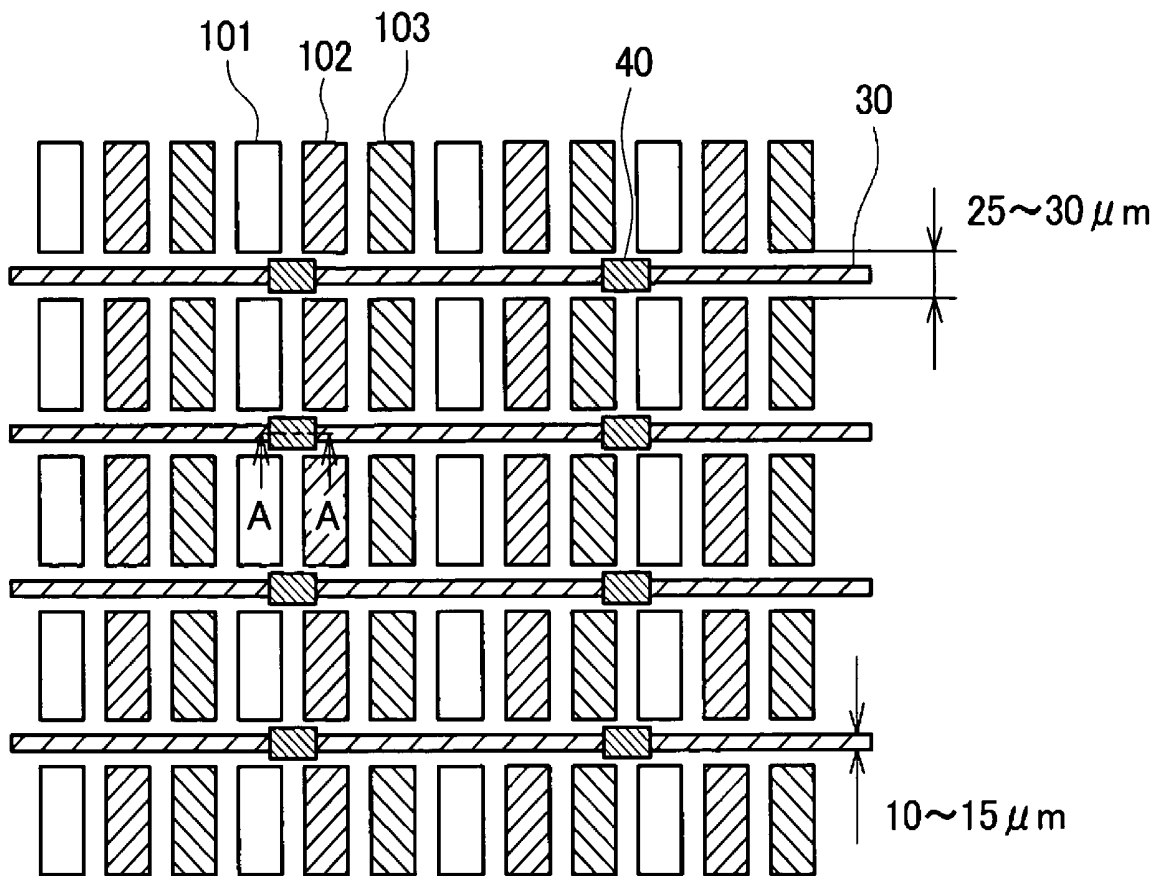

FIG. 8





## ORGANIC ELECTRO-LUMINESCENT DISPLAY DEVICE

### CLAIM OF PRIORITY

The present application claims priority from Japanese Application JP 2007-264503 filed on Oct. 10, 2007, the content of which is hereby incorporated by reference into this application.

### BACKGROUND OF THE INVENTION

#### 1. Field of the Invention

The present invention relates to an organic electro-luminescent (EL) display device, and more particularly to a top-emission-type organic EL display device which can enhance the uniformity of brightness and can enhance the reliability of the organic EL display device.

#### 2. Description of the Related Art

An organic EL display device is classified into a bottom-emission-type organic EL display device in which light emitted from organic EL layers is taken out in the direction of a glass substrate on which the organic EL layers and the like are formed and a top-emission-type organic EL display device in which light emitted from organic EL layers is taken out in the direction opposite to a glass substrate on which the organic EL layers and the like are formed. The top-emission-type organic EL display device has an advantage that the respective organic EL layers can ensure a large area thus increasing the brightness of a display.

In the organic EL display device, the organic EL layer is sandwiched between a lower electrode and an upper electrode, and emission of light from the organic EL layer is controlled by applying a fixed voltage to the upper electrode and by applying a data signal voltage to the lower electrode thus forming an image. The supply of the data signal voltage to the lower electrode is performed via a thin film transistor (TFT). In the top-emission-type organic EL display device, it is also possible to form the organic EL layer on the TFT and the like and hence, a light emission area of the display can be increased.

The top-emission-type organic EL display device radiates light toward the upper electrode side and hence, it is necessary to make the upper electrode transparent. As a transparent electrode, an ITO (Indium Tin Oxide) film, an IZO (Indium Zinc Oxide) film or the like which is a metallic oxide conductive film is used in general. However, ITO, IZO or the like exhibits high resistance compared to metal. Accordingly, when a distance between the upper electrode and a terminal portion which supplies an electric current to the upper electrode is increased, a potential of the upper electrode arranged in the vicinity of the terminal portion and a potential of the upper electrode remote from the terminal portion differ from each other. This difference appears as the non-uniformity of brightness thus deteriorating an image quality.

JP-A-2002-318556 (patent document 1) and JP-A-2001-230086 (patent document 2) disclose a top-emission-type organic EL display device in which an auxiliary electrode is provided for suppressing a phenomenon that a potential of an upper electrode differs depending on a position of the upper electrode due to resistance of the upper electrode.

### SUMMARY OF THE INVENTION

In the technique disclosed in patent document 1, the auxiliary line is formed using low-resistance metal below a bank formed between pixels and pixels. Then, a through hole is

formed in the bank so as to electrically connect an upper electrode and the auxiliary line with each other via the through hole. The auxiliary line exhibits low resistance and hence, even in a pixel which is remote from a terminal portion, it is possible to suppress the lowering of a potential of the upper electrode. However, in the above-mentioned technique, patterning of the auxiliary line becomes necessary in forming the auxiliary line below the bank. Patterning of the auxiliary lines is performed by photolithography and hence, a manufacturing cost is pushed up. Further, the connection at a through hole portion formed in the bank is performed only by the upper electrode. The through hole formed in the bank is deep and hence, it is difficult to acquire the reliable conduction at the through hole portion.

In the technique disclosed in patent document 2, the upper electrodes are divided into literal upper electrodes which are formed on the organic EL layer and wiring portions (auxiliary electrodes) which supply an electric current to the upper electrodes from terminal portions, and the wiring portions are formed using metal which exhibits low resistance. This technique also requires patterning of the auxiliary electrodes. Patterning of the auxiliary electrodes is performed by photolithography and hence, a manufacturing cost is pushed up. Further, in the above-mentioned technique disclosed in patent document 2, although the bank is not formed between the pixels and the pixels, when the bank is formed, in the same manner as patent document 1, a drawback on the conduction at the through hole arises.

The present invention has been made to realize a top-emission-type organic EL display device which, in using an auxiliary electrode for preventing a voltage drop of an upper electrode due to large resistance of the upper electrode, can suppress the rise of a manufacturing cost and, at the same time, can ensure the reliable conduction at a through hole portion.

The present invention has been made to overcome the above-mentioned drawbacks. According to the present invention, an auxiliary electrode is formed above or below an upper electrode by vapor deposition or sputtering for suppressing a voltage drop of the upper electrode. The connection between a current supply line which supplies an electric current to the upper electrode and is formed in the same layer as a drain line and the auxiliary electrode is performed via a through hole formed in an insulation film. For suppressing a connection failure at the through hole or a phenomenon that the resistance is increased at the through hole, a contact electrode made of metal is formed on the through hole portion by mask vapor deposition or sputtering in an overlapping manner with the auxiliary electrode. Following are specific means for overcoming the above-mentioned drawbacks.

(1) The present invention provides an organic EL display device having a display region on which pixels each having an organic EL layer sandwiched by an upper electrode and a lower electrode are arranged in a matrix array, wherein the upper electrode is formed of a transparent electrode, an auxiliary electrode which is conductive with the upper electrode extends between the pixels and the pixels, the auxiliary electrode is connected with a current supply line which supplies an electric current to the upper electrode via a through hole formed in an insulation layer, and a contact electrode is formed on the through hole in an overlapping manner with the auxiliary electrode.

(2) In the organic EL display device having the above-mentioned constitution (1), the contact electrode is made of metal, and has a film thickness larger than a film thickness of the auxiliary electrode.

(3) In the organic EL display device having the above-mentioned constitution (1), the auxiliary electrode is formed by mask vapor deposition or mask sputtering, and the contact electrode is formed by mask vapor deposition or mask sputtering.

(4) In the organic EL display device having the above-mentioned constitution (1), the contact electrode is formed above the auxiliary electrode.

(5) In the organic EL display device having the above-mentioned constitution (1), the contact electrode and the auxiliary electrode are made of the same material.

(6) In the organic EL display device having the above-mentioned constitution (1), the auxiliary electrode is formed over the upper electrode.

(7) In the organic EL display device having the above-mentioned constitution (1), the auxiliary electrode is formed below the upper electrode.

(8) The present invention also provides an organic EL display device having a display region on which pixels each having an organic EL layer sandwiched by an upper electrode and a lower electrode are arranged in a matrix array, wherein the upper electrode is formed of a transparent electrode, an auxiliary electrode which is conductive with the upper electrode extends between the pixels and the pixels, the auxiliary electrode is connected with a current supply line which supplies an electric current to the upper electrode via a through hole formed in an insulation layer outside the display region, and a contact electrode is formed on the through hole in an overlapping manner with the auxiliary electrode, and the contact electrode is configured to cover the plurality of through holes in common.

(9) In the organic EL display device having the above-mentioned constitution (8), the auxiliary electrode is formed by mask vapor deposition or mask sputtering, and the contact electrode is formed by mask vapor deposition or mask sputtering.

(10) The present invention also provides an organic EL display device having a display region on which pixels each having an organic EL layer sandwiched by an upper electrode and a lower electrode are arranged in a matrix array, wherein the upper electrode is formed of a transparent electrode, an auxiliary electrode which is conductive with the upper electrode extends between the pixels and the pixels, the auxiliary electrode is connected with a current supply line which supplies an electric current to the upper electrode via a through hole formed in an insulation layer within the display region and between the pixels and the pixels, and a contact electrode is formed on the through hole in an overlapping manner with the auxiliary electrode.

(11) In the organic EL display device having the above-mentioned constitution (10), a width of the contact electrode is set larger than a width of the auxiliary electrode.

(12) In the organic EL display device having the above-mentioned constitution (10), a bank is formed between the pixels and the pixels, the auxiliary electrode is formed on the bank, and the through hole is formed in the bank and other insulation layer in a penetrating manner.

(13) In the organic EL display device having the above-mentioned constitution (10), the auxiliary electrode is formed by mask vapor deposition or mask sputtering, and the contact electrode is formed by mask vapor deposition or mask sputtering.

According to the present invention, the auxiliary electrodes are formed by mask vapor deposition or mask sputtering and hence, the formation of the auxiliary electrodes requires no

photolithography step thus realizing the formation of the auxiliary electrodes without largely pushing up a manufacturing cost.

Further, although the connection between a current supply line which supplies an electric current to the upper electrode and the auxiliary electrode is established via the through hole formed in the insulation film, the through hole is extremely deep in general and hence, the conduction failure is liable to occur. According to the present invention, in place of establishing the connection with the current supply line using only the auxiliary electrode formed on the through hole, the contact electrode is formed in an overlapping manner with the auxiliary electrode at the through hole and hence, it is possible to prevent the occurrence of conduction failure at the contact portion.

In this manner, according to the present invention, it is possible to suppress a phenomenon that a potential of the upper electrode differs depending on a place and, at the same time, it is possible to enhance reliability of conduction between the current supply line and the upper electrode. Accordingly, it is possible to provide a top-emission-type organic EL display device which exhibits excellent uniformity of brightness and high reliability.

#### BRIEF DESCRIPTION OF THE DRAWINGS

FIG. 1 is a plan view of a display region of an organic EL display device according to an embodiment 1;

FIG. 2 is a cross-sectional view taken along a line A-A in FIG. 1;

FIG. 3 is a plan view of a periphery of the display region of the organic EL display device according to the embodiment 1;

FIG. 4 is a cross-sectional view of a through hole portion of the embodiment 1;

FIG. 5 is a view showing another embodiment of a cross-sectional view taken along a line A-A in FIG. 1 of the embodiment 1;

FIG. 6 is a cross-sectional view of the pixel structure of an embodiment 2;

FIG. 7 is a cross-sectional view of a through hole portion of the embodiment 2;

FIG. 8 is a plan view of a display region of an organic EL display device according to an embodiment 3; and

FIG. 9 is a cross-sectional view of a through hole portion of the embodiment 3.

#### DESCRIPTION OF THE PREFERRED EMBODIMENTS

Hereinafter, the present invention is explained in detail in conjunction with embodiments.

##### Embodiment 1

FIG. 1 is a plan view of a display region of a top-emission-type organic EL display device according to the present invention. FIG. 2 is a cross-sectional view taken along a line A-A in FIG. 1. In FIG. 1, a red pixel 101, a green pixel 102 and a blue pixel 103 are arranged sequentially in the lateral direction. The pixels having the same color are arranged in the longitudinal direction. Each pixel includes an organic EL layer 22 which emits color of red, green or blue. Each organic EL layer 22 is covered with an IZO film which constitutes a transparent electrode forming an upper electrode 23. The transparent electrode may be also formed of an ITO film or the like besides the IZO film.

An auxiliary electrode **30** extends in the lateral direction between the pixels and the pixels arranged in the longitudinal direction. The auxiliary electrode **30** is formed on the upper electrode **23** formed in a matted manner by mask vapor deposition. In the present invention, the auxiliary electrode **30** is formed by vapor deposition using a mask or sputtering and hence, a photolithography step is unnecessary for forming the auxiliary electrode **30** whereby the present invention is advantageous in cost. A distance between the pixels and the pixels in the longitudinal direction is approximately 25  $\mu\text{m}$  to 30  $\mu\text{m}$ . Accordingly, a width of the auxiliary electrode **30** is smaller than the distance between the pixels and the pixels. That is, the width of the auxiliary electrode **30** is set to 10  $\mu\text{m}$  to 15  $\mu\text{m}$ . Vapor deposition of the auxiliary electrode **30** having such an extent of width becomes possible by mask vapor deposition or sputtering.

Since it is necessary to set the resistance of the auxiliary electrode **30** to a small value, the auxiliary electrode **30** is formed using metal. As a material of the auxiliary electrode **30**, Al, Al alloy, Zn, Mg or the like can be named. Since Al or Al alloy exhibits low resistance, these materials can be preferably used for forming the auxiliary electrode **30**. Further, these materials can be easily applied to the upper electrode **23** by vapor deposition, sputtering or the like. Zn can be applied to the upper electrode **23** by resistance heating, induction heating, EB vapor deposition or sputtering. Further, when Zn is used as a material of the auxiliary line, the auxiliary line exhibits black color and hence, the auxiliary line plays a role of a black matrix thus contributing to the enhancement of contrast of an image quality. Mg can be applied to the upper electrode **23** by resistance heating, induction heating, EB vapor deposition or sputtering.

By setting the sheet resistance on a display region after the auxiliary lines are formed to 10  $\Omega/\square$  or less, it is possible to suppress a phenomenon that a potential of the upper electrode **23** differs depending on a place. In this case, the sheet resistance is the sheet resistance of the combination of the auxiliary electrodes **30** and the upper electrodes **23**. That is, the sheet resistance is largely decreased compared to the sheet resistance of a case in which only the upper electrodes **23** are provided.

FIG. 2 is a cross-sectional view taken along a line A-A in FIG. 1. In FIG. 2, a bottom-gate-type thin film transistor (TFT) is formed on an element substrate **10** made of glass. Although the bottom-gate-type TFT is used in the constitution shown in FIG. 2, as explained later, a top-gate-type TFT may also be used.

In FIG. 2, a gate electrode **15** is formed on the element substrate **10**. A gate insulation film **14** made of SiN is formed on the element substrate **10** so as to cover the gate electrode **15**. A semiconductor layer **13** is formed over the gate electrode **15**. The semiconductor layer **13** forms a channel portion of the TFT. Although a source electrode or a drain electrode (SD electrode **17**) is arranged on the semiconductor layer **13**, an n+Si layer not shown in the drawing is formed between the semiconductor layer **13** and the SD electrode **17** for ensuring an ohmic contact.

After etching a portion of the n+Si layer and a portion of the semiconductor layer **13** of the channel portion by channel etching, an organic passivation film **19** is formed. In FIG. 2, the passivation film is constituted of only the organic passivation film **19**. However, there may be a case that an inorganic passivation film **18** made of SiN or the like may be formed below the organic passivation film **19**. Since the organic passivation film **19** also plays a role of a leveling film, the organic passivation film **19** has a large thickness of approximately 1 to 4  $\mu\text{m}$ .

A reflection electrode **24** made of Al or Al alloy is formed on the organic passivation film **19**. Since the present invention relates to the top-emission-type organic EL display device, it is necessary to radiate light from the organic EL layer **22** in the direction opposite to the element substrate **10** and hence, it is necessary to form the reflection electrode **24** on the organic passivation film **19**. A through hole is formed in the organic passivation film **19** so as to make the reflection electrode **24** and the SD electrode **17** of the TFT conductive with each other.

The organic EL layer **22** of this embodiment corresponds to a top-cathode-type display device. In this case, it is necessary to use a lower electrode **21** having a large work function. Al or Al alloy used as a material for forming the reflection electrode **24** has a relatively small work function and hence, Al or Al alloy is not suitable as a material of an anode. Accordingly, the lower electrode **21** made of IZO is formed on the reflection electrode **24**.

The organic EL layer **22** which emits light is formed on the lower electrode **21**. The organic EL layer **22** is, in general, constituted of five layers consisting of a hole injection layer, a hole transport layer, a light emission layer, an electron transport layer, and an electron injection layer. The respective layers of the organic EL layer **22** are extremely thin. Although thicknesses of the respective layers differ depending on color of emitted light, the thickness of the hole transport layer is 120 nm to 250 nm, the thickness of the light emission layer is 30 nm to 40 nm, the thickness of the electron transport layer is 10 nm, and the thickness of the electron injection layer is approximately 60 nm. In this manner, even when the organic EL layer is formed by stacking these five layers, the organic EL layer is extremely thin. Accordingly, when a step portion exists on a back ground, a broken step of the film easily occurs.

To prevent such a broken step of the organic EL layer **22**, a bank **20** is formed between the respective pixels. The bank **20** is, in general, formed of an acrylic film, a polyimide film or the like which constitutes an organic film. The bank **20** prevents the organic EL layer **22** from being broken at an end portion thereof due to a stepped portion.

A transparent conductive film made of IZO which constitutes the upper electrode **23** is formed on the organic EL layers **22**. The IZO film is formed on the whole display part including portions above the banks **20** by vapor deposition. Light from the organic EL layer **22** is radiated to the outside through the IZO film which constitutes the upper electrode **23** and hence, it is necessary to increase optical transmissivity of the IZO film. Because of such a condition, the IZO film cannot have a large film thickness and hence, the film thickness of the IZO film is set to approximately 30 nm. Accordingly, the sheet resistance of the IZO is high and hence, a voltage drop of the upper electrode **23** is induced thus giving rise to a phenomenon that a potential of the upper electrode differs depending on a place.

To prevent such a voltage drop of the upper electrode **23**, the auxiliary electrode **30** is formed on the bank **20**. This is because so long as the auxiliary electrode **30** is formed on the bank **20**, there is no possibility that the auxiliary electrode **30** interrupts outputting of light from the organic EL layer **22**. As has been explained in conjunction with FIG. 1, the auxiliary electrode **30** is formed in a laterally strip shape using metal which exhibits low resistance. A film thickness of the auxiliary electrode **30** is approximately 150 nm and hence, the film thickness of the auxiliary electrode **30** is large compared to the film thickness of the upper electrode **23**. Further, the auxiliary electrode **30** is made of metal and hence, the auxiliary electrode **30** exhibits extremely small resistivity com-

pared to resistivity of the upper electrode **23** made of metal oxide. Accordingly, it is possible to prevent the voltage drop of the upper electrode **23** with the use of the auxiliary electrode **30**.

The auxiliary electrode **30** requires a contact portion for supplying an electric current to the upper electrode **23**. In this embodiment, as shown in FIG. 3, the contact portion is arranged outside the display part in the lateral direction. In the contact portion, it is necessary to form a through hole in an insulation film and to connect the auxiliary electrode **30** and a current supply line **175** with each other via the through hole. Accordingly, the reliability of the through hole portion is important.

In this embodiment, in the contact portion, in addition to the auxiliary electrode **30**, a contact electrode **40** is separately formed by vapor deposition or sputtering thus enhancing the reliability of the through hole portion. FIG. 4 is a cross-sectional view taken along a line A-A in FIG. 3. In FIG. 4, the gate insulation film **14** is formed on the element substrate **10**. The current supply line **175** is formed on the gate insulation film **14**. The current supply line **175** is arranged on the same layer as the SD electrode **17** and is formed simultaneously formed with the SD electrode **17**.

The organic passivation film **19** is formed on the current supply line **175**, and the through hole is formed in the organic passivation film **19** so as to connect the auxiliary electrode **30** and the current supply line **175**. Firstly, an IZO film which constitutes the upper electrode **23** is formed by vapor deposition so as to cover the through hole portion. Then, the auxiliary electrode **30** is formed on the upper electrode **23** by vapor deposition or sputtering.

However, a film thickness of the upper electrode **23** is approximately 30 nm, and a film thickness of the auxiliary electrode **30** is approximately 150 nm. On the other hand, a film thickness of the organic passivation film **19** is 1 μm to 4 μm, and is approximately 3 μm in many cases and hence, the film thickness of the organic passivation film **19** is extremely large.

Due to such constitution, the formed through hole is extremely deep and hence, when a broken step occurs on the upper electrode **23** or the auxiliary electrode **30**, there may be a case that the sufficient conduction cannot be acquired. Particularly, an electric current is supplied to many pixels in the contact portion and hence, an amount of an electric current which flows in the contact portion is large thus easily giving rise to a drawback on reliability of the display device when the resistance at the through hole portion increased.

In the present invention, to overcome such a drawback, as shown in FIG. 4, in the contact portion, the contact electrode **40** made of metal is further formed on the auxiliary electrode **30**. A film thickness of the contact electrode **40** is set larger than a film thickness of the auxiliary electrode **30**. Further, in the vicinity of the through hole, the contact electrode **40** is also made larger than the auxiliary electrode **30** in a planar shape. By forming the contact electrode **40** using Al, Al alloy, Zn, Mg or the like which is equal to a material of the auxiliary electrode **30**, a process for forming the contact electrode **40** can be simplified. However, the contact electrode **40** may be made of metal different from these metals.

By additionally forming the contact electrode **40** in the contact portion as in the case of this embodiment, the present invention can acquire an advantageous effect that a shape of the contact portion can be freely selected. For example, a width of the auxiliary line in the display region is restricted and hence, it is not possible to set the film thickness of the contact electrode **40** to an extremely large value. However, the film thickness of the contact electrode **40** in this embodi-

ment can be changed depending on the degree of demand for reliability. Further, a pattern of the contact electrode **40** can be increased and hence, a planar shape of the contact electrode **40** can be also freely set depending on a demand with respect to the display device.

In FIG. 3 and FIG. 4, the contact electrode is formed above the auxiliary electrode in the contact portion. As an opposite case, the auxiliary electrode may be formed below the contact electrode. The same goes for an embodiment 2 and an embodiment 3 described layer.

FIG. 5 shows the example in which the auxiliary line is formed on the IZO film which constitutes the upper electrode **23** formed on the bank **20** by vapor deposition or sputtering. This embodiment is not limited to such an example and, as shown in FIG. 5, firstly, the auxiliary electrode **30** may be formed on the bank **20** by vapor deposition and the IZO film which constitutes the upper electrode **23** maybe formed on the auxiliary electrode **30** by vapor deposition. In this example, both of the auxiliary electrode **30** and the upper electrode **23** are formed by vapor deposition and photolithography is not used and hence, there arises no problem even when either one of the auxiliary electrode **30** and the upper electrode **23** is formed first. Other constitutions of this example are equal to corresponding constitutions in the example where the auxiliary electrode **30** is formed above the upper electrode **23**.

#### Embodiment 2

The present invention is, so long as the organic EL display device is the top-emission-type organic EL display device, applicable to irrespective of whether the organic EL layer **22** is of a top anode type or of a top cathode type and irrespective of whether the TFT is of a bottom gate type or of a top gate type. This embodiment is an example in which the present invention is applied to the case where the TFT is of a top gate type and the organic EL layer **22** is of a top anode type. FIG. 6 is a cross-sectional view of a pixel portion of this embodiment. FIG. 6 corresponds to a cross-sectional view taken along a line B-B in FIG. 1.

In FIG. 6, a first background film **11** made of SiN and a second background film **12** made of SiO<sub>2</sub> are formed on an element substrate **10**. These background films **11**, **12** are provided for preventing impurities from a glass substrate from contaminating a semiconductor layer **13**. The semiconductor layer **13** is formed on the second background film **12**. With respect to the semiconductor layer **13**, after forming an a-Si film by CVD, the a-Si film is converted into a poly-Si film by radiation of laser beams.

A gate insulation film **14** made of SiO<sub>2</sub> is formed so as to cover the semiconductor layer **13**. A gate electrode **15** is formed at a position where the gate electrode **15** faces the semiconductor layer **13** in an opposed manner with the gate insulation films **14** sandwiched therebetween. Using the gate electrode **15** as a mask, impurities such as phosphorous or boron are implanted into the semiconductor layer **13** thus imparting conductivity to the semiconductor layer **13** whereby a source portion or a drain portion is formed in the semiconductor layer **13**.

An interlayer insulation film **16** made of SiO<sub>2</sub> is formed so as to cover the gate electrode **15**. The interlayer insulation film **16** is provided for ensuring insulation between the gate line or the gate electrode **15** and a drain line **171**. The drain line **171** is formed on the interlayer insulation film **16**. The drain line **171** is connected with the drain of the semiconductor layer **13** via through hole formed in the interlayer insulation film **16** and the gate insulation film **14**.

Thereafter, to protect the TFT, an inorganic passivation film **18** made of SiN is formed. An organic passivation film **19** is formed on the inorganic passivation film **18**. The organic passivation film **19** plays a role of more completely protecting the TFT together with the inorganic passivation film **18** and, at the same time, plays a role of leveling a surface on which the organic EL layer **22** is formed. Accordingly, the organic passivation film **19** has a large thickness of 1 to 4  $\mu\text{m}$ .

A reflection electrode **24** made of Al or Al alloy is formed on the organic passivation film **19**. Since Al or Al alloy exhibits high reflectance, Al or Al alloy is preferable as a material of the reflection electrode **24**. The reflection electrode **24** is connected with the drain line **171** via a through hole formed in the organic passivation film **19** and the inorganic passivation film **18**.

This embodiment provides the top-anode-type organic EL display device and hence, a lower electrode **21** of the organic EL layer **22** constitutes a cathode. Accordingly, Al or Al alloy used for forming the reflection electrode **24** is also used for forming the lower electrode **21** of the organic EL layer **22**. This is because Al or Al alloy has a relatively small work function and hence, Al or Al alloy can be used for forming a part which functions as a cathode.

The organic EL layer **22** is formed on the lower electrode **21**. In this embodiment, the order of stacked layers of the organic EL layer **22** differs from the corresponding order of the stacked layers of the organic EL layer **22** of the embodiment **1**. That is, the organic EL layer **22** is constituted of an electron injection layer, an electron transport layer, a light emission layer, a hole transport layer, and a hole injection layer from below. An upper electrode **23** which constitutes a cathode is formed on the organic EL layer **22**. Also in case of the top-anode-type organic EL display device, IZO can be used for forming the upper electrode **23**. In a display region, an IZO film is formed over the whole display region by vapor deposition without using a mask. In the same manner as the embodiment **1**, a thickness of the IZO film is set to approximately 30 nm for maintaining optical transmissivity.

In the same manner as the embodiment **1**, to prevent the rupture of the organic EL layer **22** at an end portion thereof by a broken step, a bank **20** is formed between pixels and pixels. Further, the planar structure of the pixel is substantially equal to the planar structure of the pixel shown in FIG. **1** of the embodiment **1**. In the same manner as the structure shown in FIG. **2** and FIG. **5**, the auxiliary electrode **30** in this embodiment can be formed above the bank **20** and either above or below the upper electrode **23**.

Further, in the same manner as the structure shown in FIG. **3**, a contact portion with a current supply line **175** is also formed outside the display region in the lateral direction. FIG. **7** is a cross-sectional view of a contact portion of this embodiment. FIG. **7** shows a cross section corresponding to the cross section taken along a line A-A in FIG. **3**. In FIG. **7**, the first background film **11** and the second background film **12** are formed on the element substrate **10**. The gate insulation film **14** and the interlayer insulation film **16** are formed on these background films **11**, **12**. Functions, materials and the like of the respective layers of this embodiment are equal to the functions, materials and the like of the respective layers explained in conjunction with FIG. **6**.

The current supply line **175** is provided on the interlayer insulation film **16**. The current supply line **175** is arranged on the same layer as the drain line and is formed simultaneously with the drain line. The inorganic passivation film **18** is formed so as to cover the current supply line **175**, and the organic passivation film **19** is formed on the inorganic passivation film **18**. The auxiliary electrode **30** extends over the

organic passivation film **19**. In this embodiment, outside the display region, an acrylic resin or polyimide resin for forming the bank is removed.

A through hole is formed in the organic passivation film **19** and the inorganic passivation film **18** for connecting the auxiliary electrode **30** and the current supply line **175** with each other. An IZO film which constitutes an upper electrode is formed by vapor deposition so as to cover the through hole and, thereafter, the auxiliary electrode **30** is formed by vapor deposition or sputtering thus connecting the upper electrode **23** and the current supply line **175**. To ensure the more reliable connection at the through hole portion, the contact electrode **40** is formed so as to cover the auxiliary electrode **30** at the through hole portion. In the same manner as the embodiment **1**, the contact electrode **40** is formed by mask vapor deposition or sputtering.

The contact electrode **40** is made of metal and has a film thickness which is larger than a film thickness of the auxiliary electrode **30**. Accordingly, it is possible to ensure the conduction between the current supply line **175** and the upper electrode **23** in the contact hole. In this manner, this embodiment is applicable without any problem irrespective of whether the organic EL layer **22** is of a top anode type or of a top cathode type or irrespective of whether the TFT is of a bottom gate type or of a top gate type. Further, in either case, it is possible to realize a highly reliable top-emission-type organic EL display device which can exhibit uniform screen brightness.

#### Embodiment 3

In the embodiment **1** and the embodiment **2**, the supply of the electric current to the auxiliary electrodes **30** is collectively performed by providing a bus-like contact electrode **40** outside the display region in the lateral direction. The present invention is not limited to such cases, and is also applicable to a case in which the current supply line **175** and the auxiliary electrodes **30** are connected with each other within the display region. FIG. **8** is a plan view of the display region of this embodiment.

In FIG. **8**, the pixels are arranged in the same manner as the pixels shown in FIG. **1**. Further, the auxiliary electrodes **30** extend in the lateral direction on the screen in the same manner as the auxiliary electrodes **30** shown in FIG. **1**. The embodiment **3** shown in FIG. **8** differs from the embodiment **1** shown in FIG. **1** with respect to a point that the contact of the auxiliary electrodes **30** and the current supply line is arranged within the display region. In FIG. **8**, the contact portion is formed at an intermediate point between pixels. This is because a space for forming a through hole can be easily ensured in such a portion. The through hole is formed in a bank **20**.

In FIG. **8**, the contact portion is formed in all auxiliary electrodes **30** in the longitudinal direction, while the contact portion is formed for every five pixels in the lateral direction. Intervals of the formation of the contact portions may be determined based on the degree of difference in potentials of the upper electrodes **23** which is determined based on a size of a screen or the like. A width of the contact portion is set larger than a width of the auxiliary electrode **30**. Such width setting is made to suppress the increase of resistance at the through hole portion as much as possible. Further, a width of the contact electrode **40** which is formed at the through hole in an overlapping manner with the auxiliary electrode **30** is set larger than a width of the auxiliary electrode **30** at a place other than the through hole.

FIG. **9** is a cross-sectional view taken along a line A-A in FIG. **8**. A cross section shown in FIG. **9** corresponds to a cross

section when the top-gate-type TFT is formed as shown in FIG. 6. That is, on an element substrate **10** made of glass, a first background film **11**, a second background film **12**, a gate insulation film **14**, and an interlayer insulation film **16** are formed. Further, a current supply line **175** is formed in the interlayer insulation film **16**. An inorganic passivation film **18** and an organic passivation film **19** are formed so as to cover the current supply line **175**. Further, in view of the relationship that an auxiliary line is formed on the bank **20**, in FIG. 9, the bank **20** is formed on the organic passivation film **19**.

A through hole is formed in the bank **20**, the organic passivation film **19** and the inorganic passivation film **18** in a penetrating manner. Such a through hole is formed for connecting the auxiliary line and the current supply line **175** with each other. Since the through hole is formed in the bank **20** in this embodiment, the through hole becomes extremely deep. That is, when the bank **20** is formed of an organic film, a film thickness of the bank **20** is approximately 2  $\mu\text{m}$ , a film thickness of the organic passivation film **19** is approximately 3  $\mu\text{m}$ , and a film thickness of the inorganic passivation film **18** is approximately 0.4  $\mu\text{m}$  and hence, the film thickness in total becomes a large thickness of 5.4  $\mu\text{m}$ . That is, a depth of the through hole becomes 5.4  $\mu\text{m}$ . In spite of the necessity for forming such a deep through hole, in view of the relationship that the through hole is formed in the bank **20**, a profile of the through hole is limited. As a result, a taper angle  $\theta$  of the through hole becomes large. When the taper angle of the through hole is large, a broken step of a conductive film is liable to occur at the through hole portion.

In FIG. 9, an upper electrode **23** is formed so as to cover the through hole. Since a film thickness of the upper electrode **23** is 30 nm, such a deep through hole may easily cause a broken step thus giving rise to conduction failure. The auxiliary electrode **30** is formed on the through hole so as to cover the upper electrode **23**. A thickness of the auxiliary electrode **30** is 150 nm. However, with such an extent of film thickness, it is not easy to ensure the conduction at the through hole having the large taper angle  $\theta$  and a large depth of 5.4  $\mu\text{m}$ . Accordingly, it is difficult to acquire the reliable conduction at the through hole portion only with the auxiliary electrode **30**.

According to the present invention, as shown in FIG. 9, a contact electrode **40** having a thickness larger than a thickness of the auxiliary electrode **30** is formed on the through hole portion so as to cover the auxiliary electrode **30**. The contact electrode **40** is formed using metal. For example, the contact electrode **40** may be formed using the same material as the auxiliary electrode **30** such as Al, Al alloy, Zn or Mg. In this manner, according to this embodiment, by forming the contact electrode **40** made of metal and having the large thickness in a contact portion, it is possible to stabilize the conduction resistance at the through hole. In this embodiment, by supplying an electric current to a display region such that the electric current is supplied to the upper electrodes **23** via the

current supply line **175** and the auxiliary electrodes **30**, the potential of the upper electrode **23** can be made more uniform compared to the case of the embodiment 1. Further, since the through hole resistance can be stabilized by the contact electrode **40** in the contact portion, the screen brightness can be made more uniform and, at the same time, the reliability of the organic EL display device can be further increased.

What is claimed is:

1. An organic EL display device having a display region on which pixels each having an organic EL layer sandwiched by an upper electrode and a lower electrode are arranged in a matrix array, wherein

the upper electrode is formed of a transparent electrode, an auxiliary electrode which is conductive with the upper electrode extends between the pixels and the pixels, the auxiliary electrode is connected with a current supply line which supplies an electric current to the upper electrode via a through hole formed in an insulation layer outside the display region, and

a contact electrode is formed on the through hole in an overlapping manner with the auxiliary electrode, and the contact electrode is configured to cover the plurality of through holes in common.

2. An organic EL display device according to claim 1, wherein the auxiliary electrode is formed by mask vapor deposition or mask sputtering, and the contact electrode is formed by mask vapor deposition or mask sputtering.

3. An organic EL display device having a display region on which pixels each having an organic EL layer sandwiched by an upper electrode and a lower electrode are arranged in a matrix array, wherein

the upper electrode is formed of a transparent electrode, an auxiliary electrode which is conductive with the upper electrode extends between the pixels and the pixels, the auxiliary electrode is connected with a current supply line which supplies an electric current to the upper electrode via a through hole formed in an insulation layer within the display region and between the pixels and the pixels,

a contact electrode is formed on the through hole in an overlapping manner with the auxiliary electrode, and a width of the contact electrode is set larger than a width of the auxiliary electrode.

4. An organic EL display device according to claim 3, wherein a bank is formed between the pixels and the pixels, the auxiliary electrode is formed on the bank, and the through hole is formed in the bank and other insulation layer in a penetrating manner.

5. An organic EL display device according to claim 3, wherein the auxiliary electrode is formed by mask vapor deposition or mask sputtering, and the contact electrode is formed by mask vapor deposition or mask sputtering.

\* \* \* \* \*

专利名称(译)	有机电致发光显示装置		
公开(公告)号	<a href="#">US7915814</a>	公开(公告)日	2011-03-29
申请号	US12/285688	申请日	2008-10-10
[标]申请(专利权)人(译)	株式会社日立显示器		
申请(专利权)人(译)	日立显示器有限公司.		
当前申请(专利权)人(译)	日立显示器有限公司. 三星DISPLAY CO., LTD.		
[标]发明人	MATSUDATE NORIHARU OOKAWARA TAKESHI		
发明人	MATSUDATE, NORIHARU OOKAWARA, TAKESHI		
IPC分类号	H01L51/50		
CPC分类号	H01L27/3276 H01L2251/5315		
优先权	2007264503 2007-10-10 JP		
其他公开文献	US20090096371A1		
外部链接	<a href="#">Espacenet</a> <a href="#">USPTO</a>		

摘要(译)

通过防止由透明导电膜形成的上电极的电压降来实现具有均匀屏幕亮度的顶部发光型有机EL显示装置。每个夹在上电极和下电极之间的像素以矩阵阵列排列以形成显示区域。辅助电极在像素和像素之间沿横向延伸，用于防止上电极的电压降。通过在绝缘层中形成通孔，使向上电极和辅助电极提供电流的电流供应线彼此导电。为了确保通孔处的连接可靠性，通过气相沉积在通孔上形成由金属制成的与辅助电极重叠的接触电极。

